

2-wheeled container systems

# MGB 240



**SULO**

# MGB 240

## Material and Design

- Polymer components injection moulded from specially designed HDPE
- Resistant to decay, frost, heat and many chemicals
- Special UV-stabilisation provides excellent ageing characteristics
- Metal components are corrosion resistant
- Quiet-running solid rubber tyres
- Suitable for all DIN lifting equipment
- Compatible with identification and weighing systems
- Fitted as standard with chip nest in accordance with RAL GZ 951/1
- Two lid options: standard lid or EURO 2 lid

## Quality

- Certified according to EN 840 and RAL GZ 951/1
- Certified management systems according to DIN EN ISO 9001 and DIN EN ISO 14001
- Constant supervision of quality through own laboratory and independent institutes
- High quality materials and most advanced manufacturing processes for long service life
- All container parts are recyclable
- Additives are cadmium free and environmentally friendly

## Safety and Handling

- Double angle rail for highest safety during emptying
- Safe and easy to manoeuvre
- Continuous handle on the body
- Special ribs prevent containers from becoming jammed when stacked
- Particularly stable due to external position of wheels
- Open wheel case prevents accumulation of dirt
- Easy to clean due to smooth surfaces and rounded internal corners
- No water ingress when opening the lid

## Colours

- Standard colours grey, green, brown, blue
- Special colours are available on request

## Accessories

- Comprehensive range of accessories in separate brochure

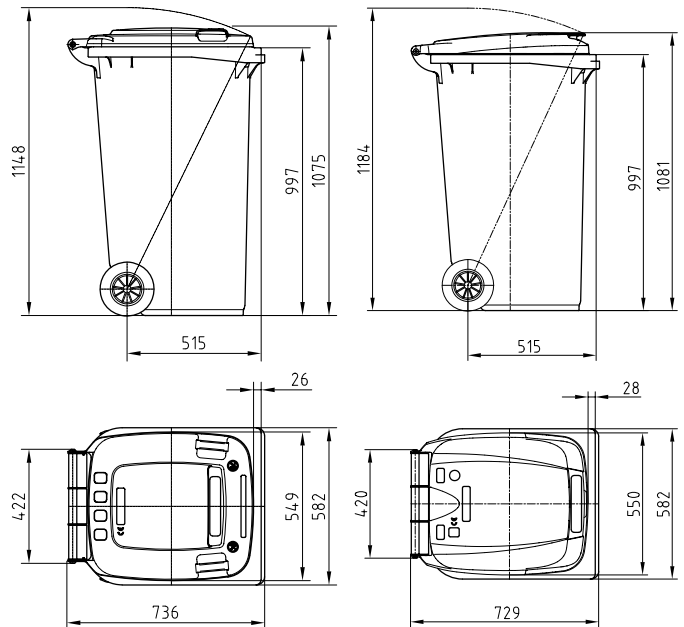

Standard lid

EURO 2 lid

all dimensions may vary due to production conditions

## Specifications

Nominal volume	Net weight	Max. load	Permitted total weight
240 litres	ca. 14 kg	96 kg	110 kg

The specified weights are a rounded average based on the standard specification. The actual weight may differ due to production conditions and different specifications.

